

REVISIONS			
SYM	DESCRIPTION	BY	DATE
A	ORIGINAL	BJD	2/16/16

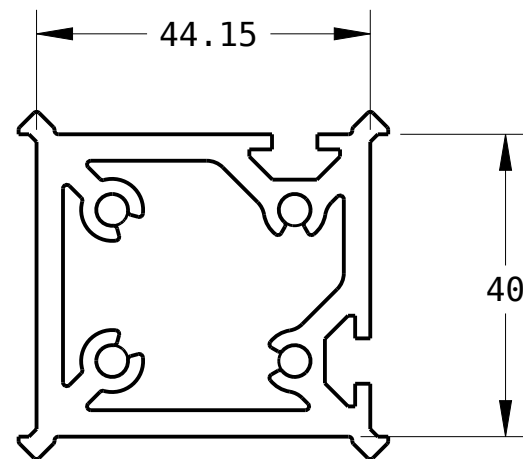

Notes:

- All profile dimensions are in millimeters and for reference only. Use Inventables supplied DXF to make tooling.
- The XXXX portion of the part number is the cut length "L" in millimeters. All 4 digits shall be used. 0200 would be 200mm long. See drawing for cut length tolerance.
- The T portion of the part number represents optional tapping.
T= tap all (4) interior holes on both ends
0 = Not tapped.
See drawing for tapping details.
- The F portion of the part number represent the finish.
B = Black Anodized
C = Clear Anodized
The finish may be applied before or after cutting and tapping
- Examples
P/N 80040-0200-T-B: 200mm Long, Tapped, Black anodized
P/N 80040-1000-0-C: 1000mm Long, No Tapping, Clear anodized



The work is licensed under a Creative Commons Attribution-Share Alike 3.0 License

DRAWN			BJD	1/6/15	Extrusion	Inventables, Inc
CHECKER						
SCALE						80040-XXXX-T-F
						SHEET 1 OF 1